

4

3

2

1

REVISION DATA

REV	DESCRIPTION	DATE
A0	NEW DRAWING	2015-12-15

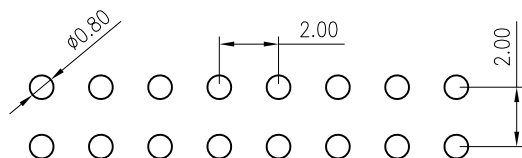
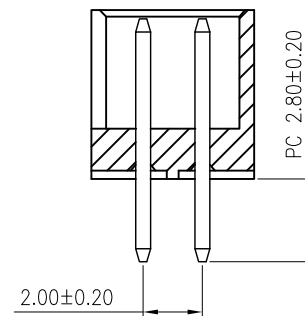
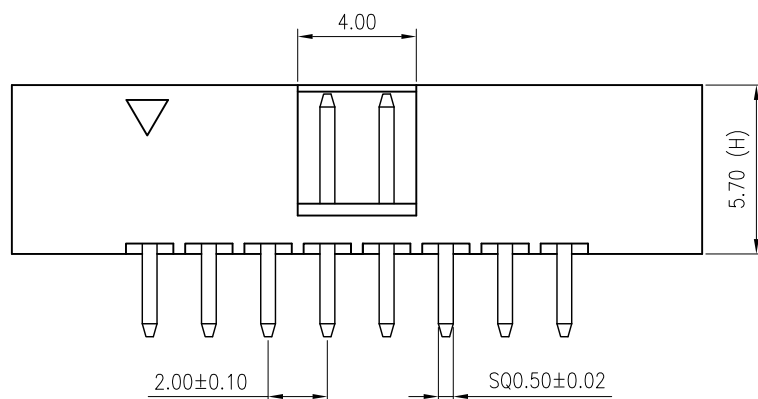
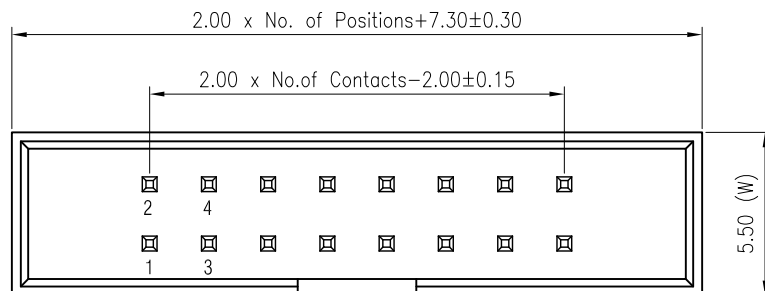

P.C.B LAYOUT

Specification

Material:

Contact Material: Brass

Contact plating: Au or Sn Over30-50u" Ni

Insulator Material: Black Polyester UL94V-0

Standard: PA6T/PA9T/LCP + 30%G.F

Electrical:

Current rating: 2.0Amps/contact max.

Contact resistance: ≤ 20mΩ/contact

Insulation resistance: ≥ 1000MΩ at V=100V

Withstanding Voltage: 500V AC/minute

Mechanical:

Operating temperature: -40°C to +105°C

Wave soldering temperature: 255 ± 5°C, 10s

PROJECT	PC (mm)
Standard	2.80
Specified	

BD01

2XX1

D

XX

X

B

N

X

D001

Product Descriptions
BD01 H5.7 W5.5No. of Positions
03-25PAngle Type
D StraightContact Plated
SN Tin120u"
MT 锡120u"
GF Gold 0.8u"
G1 Au1u"
G3 Au3u"
G4 Au5u"
G6 Au10u"
G7 Au15u"
G8 Au30u"
GA Au1.5u"
S1 半金锡1u"Insulator Material
C PA6T
E PA9T
F LCPInsulator Color
B BlackInsulator Feature
N Without PegPacking Options
A PE Bag
B Tray
C PVC Box
D TubeSeries No.
D001 L8.2mm
PC2.8

GSAMTEK® 东莞市广溯电子科技有限公司
DONGGUAN GUANG SU ELECTRONIC TECHNOLOGY CO.,LTD

TOLERANCE	PROJECTON		TITLE:
ANGLE ±5°	DATE :	2015-12-15	双排180度筒牛 PH2.0 H5.7 L8.2 PC2.8
X.XXX ±0.10	DRAWN :	SAMTEK	PART NO. BD012XX1DXXXBNXD001
X.XX ±0.20	CHECKED :		DRAWING NO.
X.X ±0.30	APPROVED :		REV: A0 UNIT: mm SCALE: 3:1 SIZE: A4
X. ±0.50			

4

3

2

1

4

3

2

1

REVISION DATA

REV	DESCRIPTION	DATE
A0	NEW DRAWING	2015-12-15

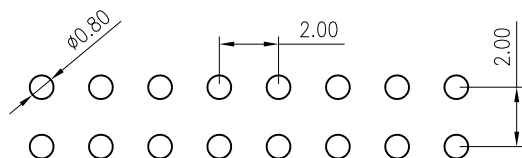
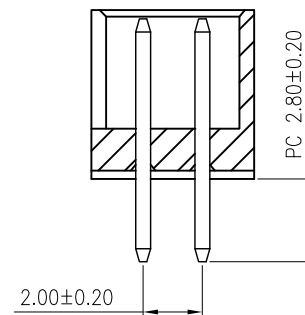
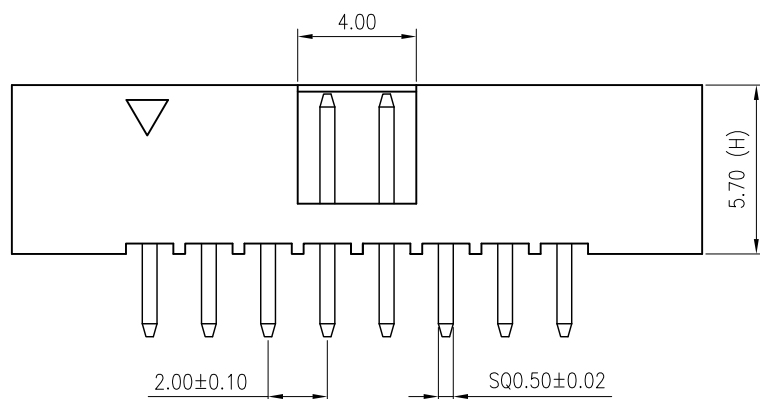
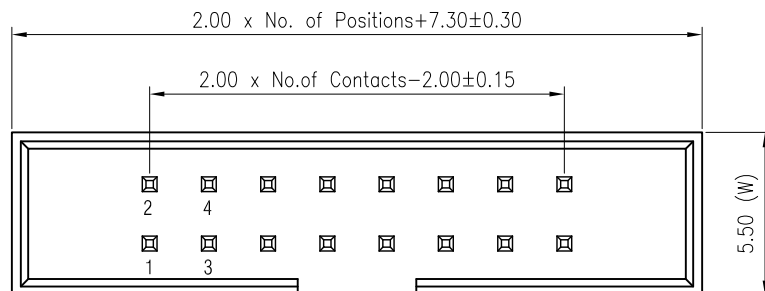

P.C.B LAYOUT

Specification

Material:

Contact Material: Brass

Contact plating: Au or Sn Over30-50u" Ni

Insulator Material: Black Polyester UL94V-0

Standard: PA6T/PA9T/LCP + 30%G.F

Electrical:

Current rating: 2.0Amps/contact max.

Contact resistance: ≤ 20mΩ/contact

Insulation resistance: ≥ 1000MΩ at V=100V

Withstanding Voltage: 500V AC/minute

Mechanical:

Operating temperature: -40°C to +105°C

Wave soldering temperature: 255 ± 5°C, 10s

PROJECT	PC (mm)
Standard	2.80
Specified	

BD01	2XX1	D	XX	X	B	N	X	D001
Product Descriptions BD01 H5.7 W5.5	No. of Positions 03-25P	Angle Type D Straight	Contact Plated SN Tin120u" MT 锡120u" GF Gold 0.8u" G1 Au1u" G3 Au3u" G4 Au5u" G6 Au10u" G7 Au15u" G8 Au30u" GA Au1.5u" S1 半金锡1u"	Insulator Material C PA6T E PA9T F LCP	Insulator Color B Black	Insulator Feature N Without Peg	Packing Options A PE Bag B Tray C PVC Box D Tube	Series No. D001 L8.2mm PC2.8

GSAMTEK® 东莞市广溯电子科技有限公司
DONGGUAN GUANG SU ELECTRONIC TECHNOLOGY CO.,LTD

TOLERANCE	PROJECTON		TITLE:
ANGLE ±5°	DATE :	2015-12-15	双排180度筒牛 PH2.0 H5.7 L8.2 PC2.8
X.XXX ±0.10	DRAWN :	SAMTEK	PART NO. BD012XX1DXXXBNXD001
X.XX ±0.20	CHECKED :		DRAWING NO.
X.X ±0.30	APPROVED :		REV: A0 UNIT: mm SCALE: 3:1 SIZE: A4
X. ±0.50			

4

3

2

1