

4

3

2

1

REVISION DATA

REV	DESCRIPTION	DATE
A0	NEW DRAWING	2018-08-02

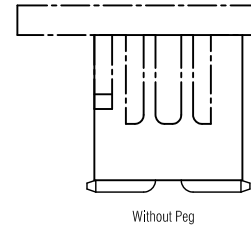
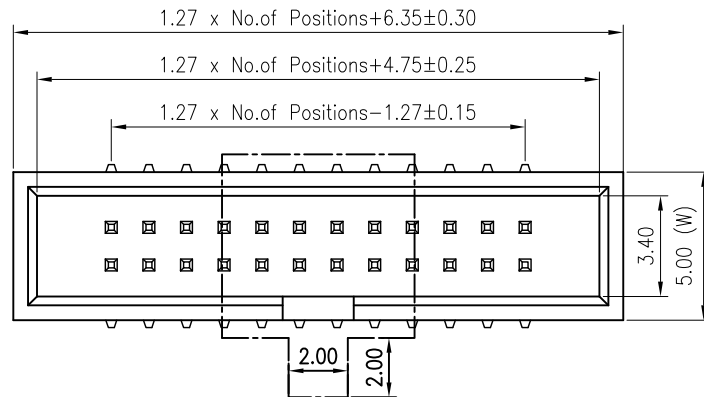

Without Peg

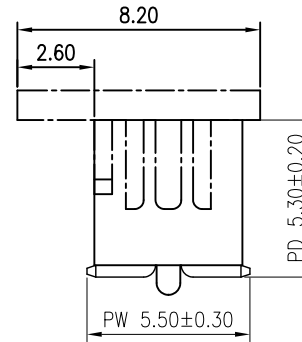
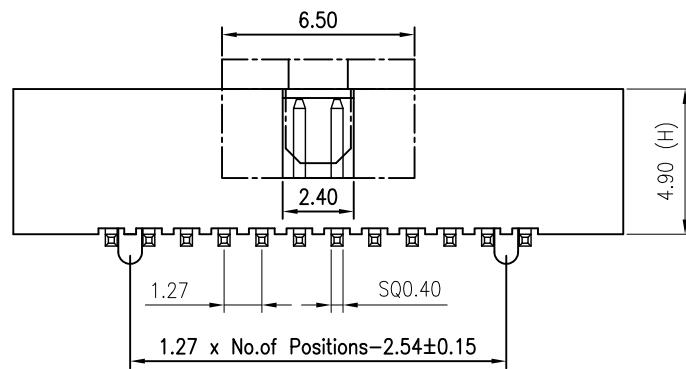

With Peg

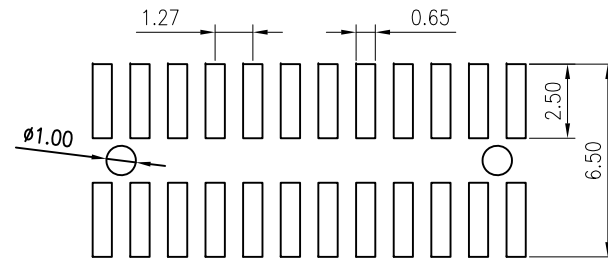

P.C.B LAYOUT

Specification

Material:

Contact Material: Brass

Contact plating: Au or Sn Over 30-50u" Ni

Insulator Material: Black Polyester UL94V-0

Standard: PA6T/PA9T/LCP + 30%G.F

Electrical:

Current rating: 1.0Amps/contact max.

Contact resistance: ≤ 20mΩ/contact

Insulation resistance: ≥ 500MΩ at V=100V

Withstanding Voltage: 300V AC/minute

Mechanical:

Operating temperature: -40°C to +105°C

Reflow soldering temperature: 260 ± 5°C, 10s

PROJECT	PD (mm)	PW (mm)
Standard	5.30	5.50
Specified		

BC03

2XX1

S

XX

X

B

N

X

S001

Product Descriptions
BC03 H4.9 W5.6No. of Positions
03-50PAngle Type
S SMT TypeContact Plated
SN Tin120u"
MT 锡锡120u"
GF Gold 0.8u"
G1 Au1u"
G3 Au3u"
G4 Au5u"
G6 Au10u"
G7 Au15u"
G8 Au30u"
GA Au1.5u"
S1 半金锡1u"Insulator Material
C PA6T
E PA9T
F LCPInsulator Color
B BlackInsulator Feature
N Without PegPacking Options
A PE Bag
C PVC Box
D Tube
E Tube+CAP
F Tape Reel
G Reel+CAPSeries No.
S001 L6.7mm
P80 PW5.5

GSAMTEK® 东莞市广溯电子科技有限公司
DONGGUAN GUANG SU ELECTRONIC TECHNOLOGY CO.,LTD

TOLERANCE	PROJECTON		TITLE:
ANGLE ±5°	DATE :	2018-08-02	双排SMT筒牛 PH1.27 H4.9 L6.7 B0 PW5.5
X.XXX ±0.10	DRAWN :	SAMTEK	PART NO. BC032XX1SXXXBNXS001
X.XX ±0.20	CHECKED :		DRAWING NO.
X.X ±0.30	APPROVED :		REV: A0 UNIT: mm SCALE: 3:1 SIZE: A4
X. ±0.50			

4

3

2

1