

P.C.B LAYOUT

REVISION DATA		
REV	DESCRIPTION	DATE
A0	NEW DRAWING	2015-07-30

Specification

Material:

Contact Material: Brass

Contact plating: Au or Sn Over 30-50u" Ni

Insulator Material: Black Polyester UL94V-0

Standard: PA6T/PA9T/LCP + 30%G.F

Electrical:

Current rating: 1.0Amps/contact max.

Contact resistance: ≤ 20mΩ/contact

Insulation resistance: ≥ 500MΩ at V=100V

Withstanding Voltage: 300V AC/minute

Mechanical:

Operating temperature: -40°C to +105°C

Wave soldering temperature: 255 ± 5°C, 10s

PROJECT	PA (mm)	H (mm)	PC (mm)
Standard	3.00	2.50	3.00
Specified			

PC12	2XX1	D	XX	X	B	N	A	DXXX
Product Descriptions PC12 H2.5 W5.0	No. of Positions 02-50P	Angle Type D Straight	Contact Plated SN Tin120u" MT 锡120u" GF Gold 0.8u" G1 Au1u" G3 Au3u" G4 Au5u" G6 Au10u" G7 Au15u" G8 Au30u" GA Au1.5u" S1 半金锡1u"	Insulator Material C PA6T E PA9T F LCP	Insulator Color B Black	Insulator Feature N Without Peg	Packing Options A PE Bag	Series No. DXXX L=PA+H+PC

GSAMTEK® 东莞市广溯电子科技有限公司
DONGGUAN GUANG SU ELECTRONIC TECHNOLOGY CO.,LTD

TOLERANCE	PROJECTON		TITLE:
ANGLE ±5°	DATE :	2015-07-30	双排180度排针 PH1.27x2.54 H2.5 系列图
X.XXX ±0.10	DRAWN :	SAMTEK	PART NO. PC122XX1DXXXBNADXXX
X.XX ±0.20	CHECKED :		DRAWING NO.
X.X ±0.30	APPROVED :		REV: A0 UNIT: mm SCALE: 3:1 SIZE: A4
X. ±0.50			

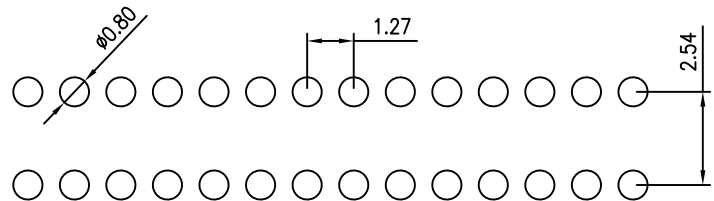
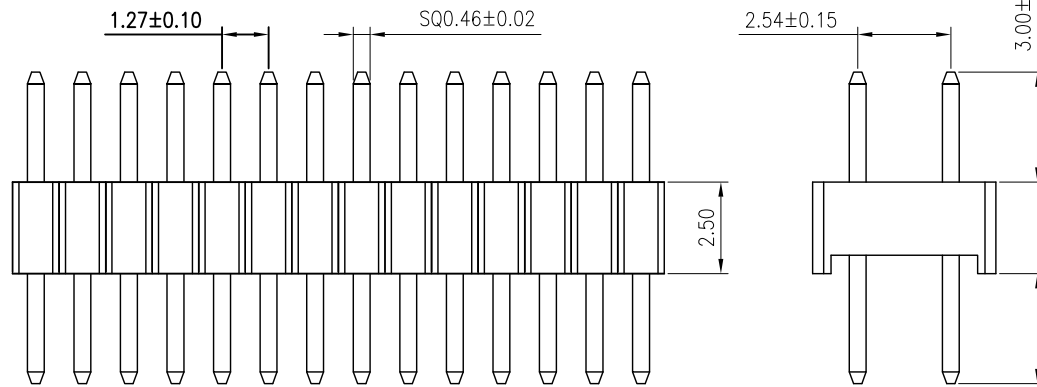
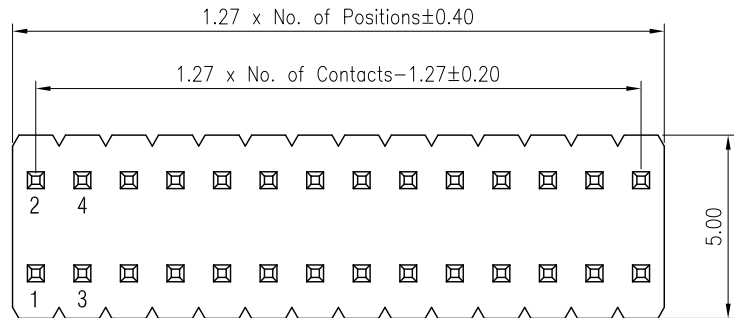

P.C.B LAYOUT

REVISION DATA		
REV	DESCRIPTION	DATE
A0	NEW DRAWING	2015-07-30

Specification

Material:

Contact Material: Brass

Contact plating: Au or Sn Over30-50u" Ni

Insulator Material: Black Polyester UL94V-0

Standard: PA6T/PA9T/LCP+30%G.F

Electrical:

Current rating: 1.0Amps/contact max.

Contact resistance: ≤20mΩ/contact

Insulation resistance: ≥500MΩ at V=100V

Withstanding Voltage: 300V AC/minute

Mechanical:

Operating temperature: -40°C to +105°C

Wave soldering temperature: 255±5°C, 10s

PC12	2XX1	D	XX	X	B	N	A	D001
Product Descriptions PC12 H2.5 W5.0	No. of Positions 02-50P	Angle Type D Straight	Contact Plated SN Tin120u" MT 锡120u" GF Gold 0.8u" G1 Au1u" G3 Au3u" G4 Au5u" G6 Au10u" G7 Au15u" G8 Au30u" GA Au1.5u" S1 半金锡1u"	Insulator Material C PA6T E PA9T F LCP	Insulator Color B Black	Insulator Feature N Without Peg	Packing Options A PE Bag	Series No. D001 L8.5mm PA3.0 PC3.0

GSAMTEK® 东莞市广溯电子科技有限公司
DONGGUAN GUANG SU ELECTRONIC TECHNOLOGY CO.,LTD

TOLERANCE	PROJECTON		TITLE:
ANGLE ±5°	DATE :	2015-07-30	双排180度排针 PH1.27x2.54 H2.5 L8.5 PA3.0 PC3.0
X.XXX ±0.10	DRAWN :	SAMTEK	PART NO. PC122XX1DXXXBNAD001
X.XX ±0.20	CHECKED :		DRAWING NO.
X.X ±0.30	APPROVED :		REV: A0 UNIT: mm SCALE: 3:1 SIZE: A4
X. ±0.50			