

REVISION DATA		
REV	DESCRIPTION	DATE
A0	NEW DRAWING	2015-06-08

## Specification

Material:

Contact Material: Brass

Contact plating: Au or Sn Over30-50u" Ni

Insulator Material: Black Polyester UL94V-0

Standard: PBT/PA6T/PA9T/LCP+30%G.F

Electrical:

Current rating: 3.0Amps/contact max.

Contact resistance:  $\leq 20m\Omega$ /contact

Insulation resistance:  $\geq 1000M\Omega$  at V=100V

Withstanding Voltage: 1000V AC/minute

Mechanical:

Operating temperature:  $-40^{\circ}C$  to  $+105^{\circ}C$

Wave soldering temperature:  $255 \pm 5^{\circ}C, 10s$

PROJECT	PA (mm)	PB (mm)	PC (mm)
Standard	6.00	1.20	6.00
Specified			

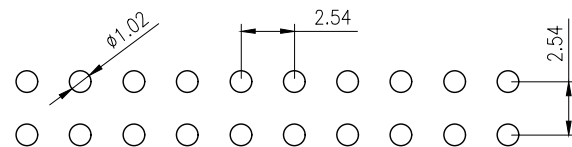
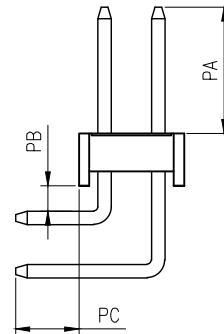
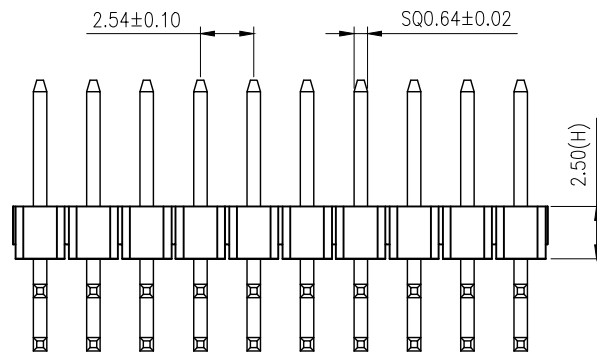
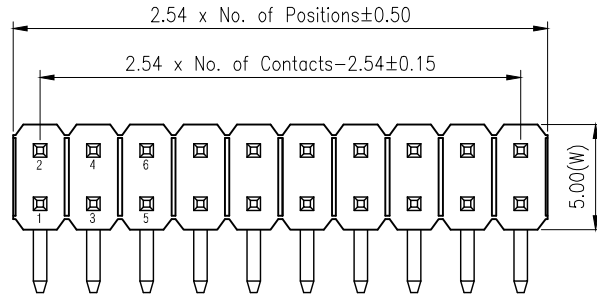

P.C.B LAYOUT

PF05	2XX1	R	XX	X	B	N	A	RXXX
Product Descriptions PF05 H2.5 W5.0	No. of Positions 02-40P	Angle Type R Right Angle	Contact Plated SN Tin120u" MT 雾锡120u" GF Gold 0.8u" G1 Au1u" G3 Au3u" G4 Au5u" G6 Au10u" G7 Au15u" G8 Au30u" GA Au1.5u" S1 半金锡1u"	Insulator Material A PBT C PA6T E PA9T F LCP	Insulator Color B Black	Insulator Feature N Without Peg	Packing Options A PE Bag	Series No. RXXX L1=PA+H+PB +PC+1.25 L2=L1+5.0

**GSAMTEK® 东莞市广溯电子科技有限公司**  
DONGGUAN GUANG SU ELECTRONIC TECHNOLOGY CO.,LTD

TOLERANCE	PROJECTON	TITLE:
ANGLE $\pm 5^{\circ}$	DATE: 2015-06-08	双排90度排针 PH2.54 H2.5 系列
X.XXX $\pm 0.10$	DRAWN: SAMTEK	PART NO. PF052XX1RXXXBNARXXX
X.XX $\pm 0.20$	CHECKED:	DRAWING NO.
X.X $\pm 0.30$	APPROVED:	REV: A0 UNIT: mm SCALE: 3:1 SIZE: A4
X. $\pm 0.50$		

REVISION DATA		
REV	DESCRIPTION	DATE
A0	NEW DRAWING	2015-06-08

## Specification

Material:

Contact Material: Brass

Contact plating: Au or Sn Over30-50u" Ni

Insulator Material: Black Polyester UL94V-0

Standard: PBT/PA6T/PA9T/LCP+30%G.F

Electrical:

Current rating: 3.0Amps/contact max.

Contact resistance:  $\leq 20m\Omega$ /contact

Insulation resistance:  $\geq 1000M\Omega$  at V=100V

Withstanding Voltage: 1000V AC/minute

Mechanical:

Operating temperature:  $-40^{\circ}C$  to  $+105^{\circ}C$

Wave soldering temperature:  $255 \pm 5^{\circ}C, 10s$

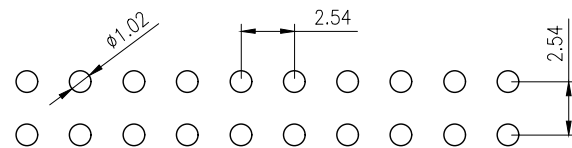
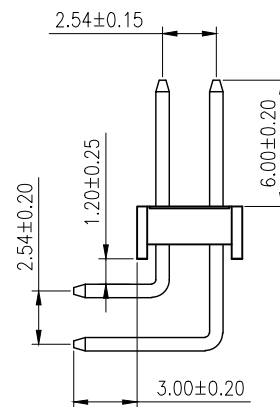
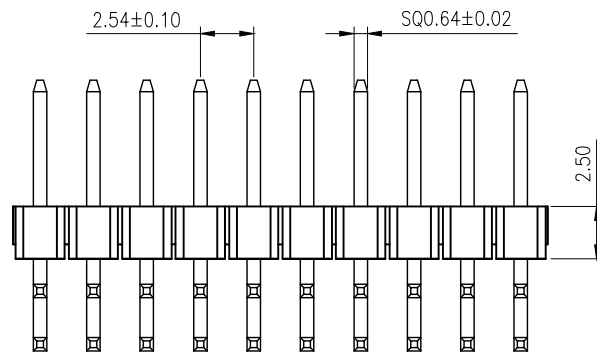
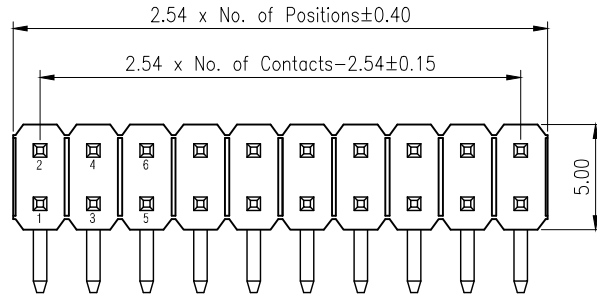

P.C.B LAYOUT

PF05	2XX1	R	XX	X	B	N	A	R001
Product Descriptions PF05 H2.5 W5.0	No. of Positions 02-40P	Angle Type R Right Angle	Contact Plated SN Tin120u" MT 雾锡120u" GF Gold 0.8u" G1 Au1u" G3 Au3u" G4 Au5u" G6 Au10u" G7 Au15u" G8 Au30u" GA Au1.5u" S1 半金锡1u"	Insulator Material A PBT C PA6T E PA9T F LCP	Insulator Color B Black	Insulator Feature N Without Peg	Packing Options A PE Bag	Series No. R001 L13.95/18.95 PA6.0 PB1.2 PC3.0

**GSAMTEK® 东莞市广溯电子科技有限公司**  
DONGGUAN GUANG SU ELECTRONIC TECHNOLOGY CO.,LTD

TOLERANCE	PROJECTON		TITLE:
ANGLE $\pm 5^{\circ}$	DATE:	2015-06-08	双排90度排针 PH2.54 H2.5 L13.95/18.95 PA6.0 PB1.2 PC3.0
X.XXX $\pm 0.10$	DRAWN:	SAMTEK	PART NO. PF052XX1RXXXBNAR001
X.XX $\pm 0.20$	CHECKED:		DRAWING NO.
X.X $\pm 0.30$	APPROVED:		REV: A0 UNIT: mm SCALE: 3:1 SIZE: A4
X. $\pm 0.50$			